

- D** Doormaster Smart 4+N Kurzbedienungsanleitung
- GB** Doormaster Smart 4+N quick guide
- I** Doormaster Smart 4+N guida rapida

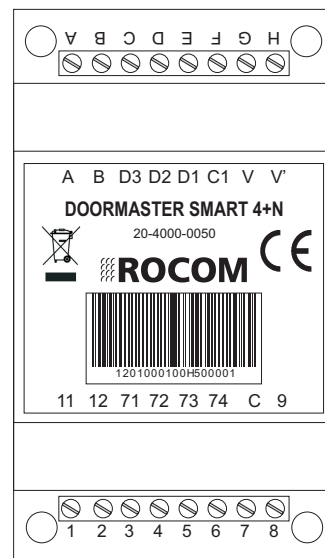

SIEDLE

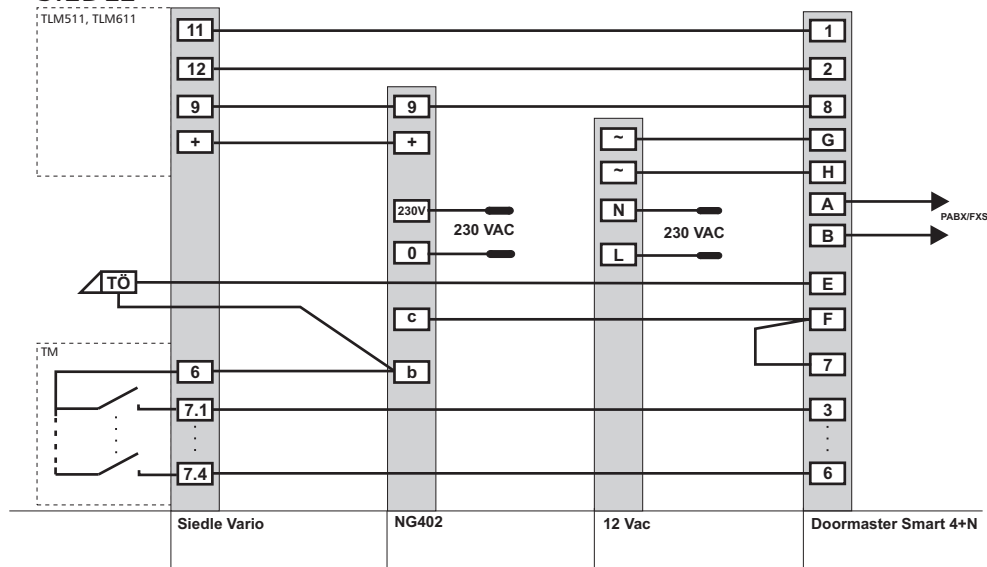

RITTO

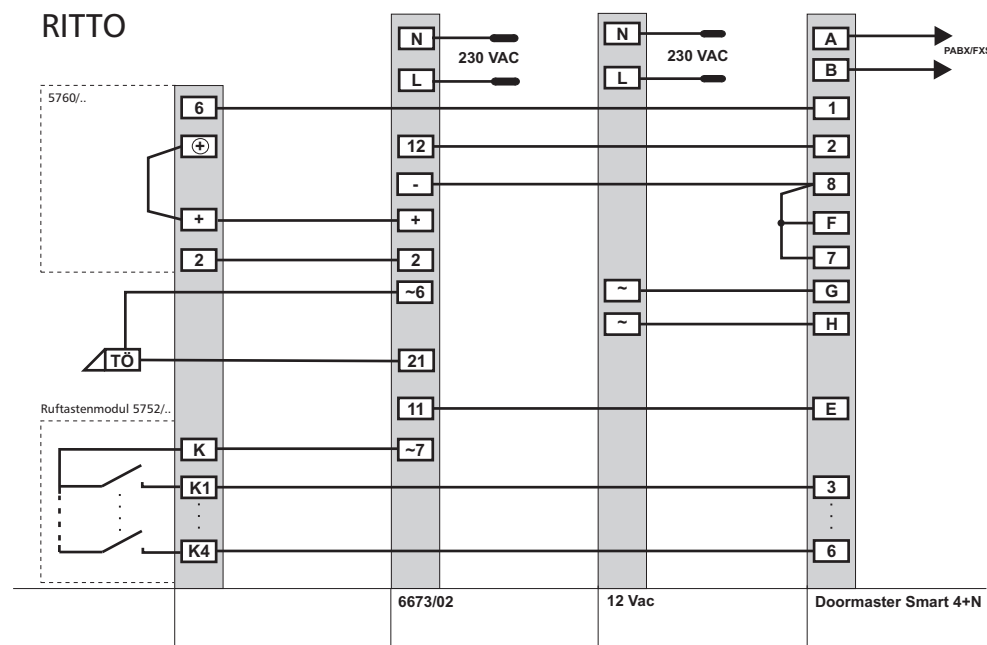

FARFISA

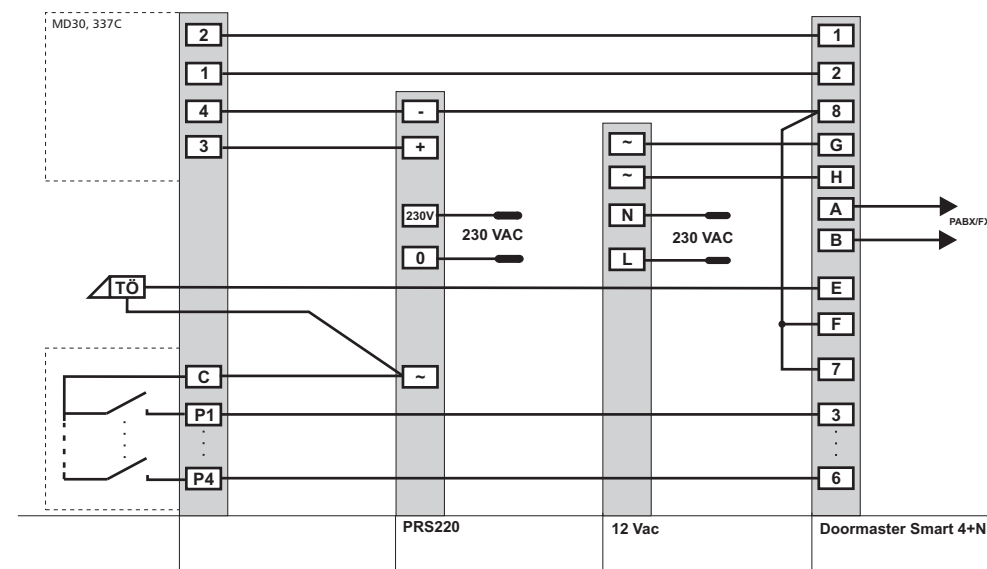

ROCOM

- D** Doormaster Smart 4+N Programmierung
- GB** Doormaster Smart 4+N programming
- I** Doormaster Smart 4+N programmazione

Programmiermodus aktivieren/activate programming mode/attivazione modalità programmazione



Grunddaten laden/load factory set up/carica dati di fabbrica



Programmierung der Rufnummern/telephon no. programming(programmazione nr. di telefono)

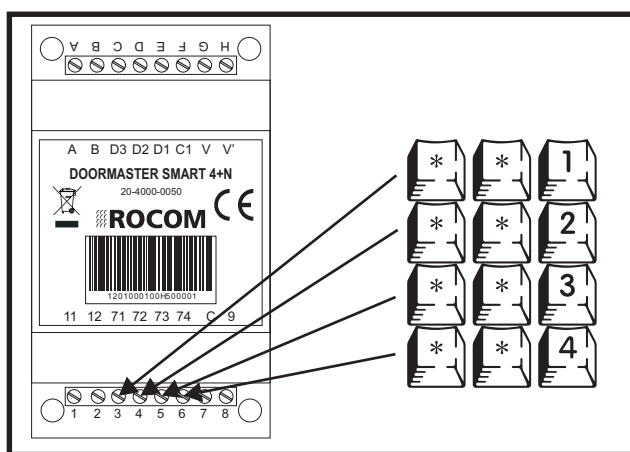

Für die Benutzung mit FritzBox sind ab Werk die Rufnummer 11(Taste1), 12(Taste2), 13(Taste3) und 14(Taste4) vorprogrammiert.



For the use with FritzBox following number are preprogrammed: 11(button 1), 12(button 2), 13(button 3) and 14(button 4).



Per l'uso con FritzBox sono preprogrammati i seguenti numeri: 11(tasto 1), 12(tasto 2), 13(tasto 3) e 14(tasto 4).

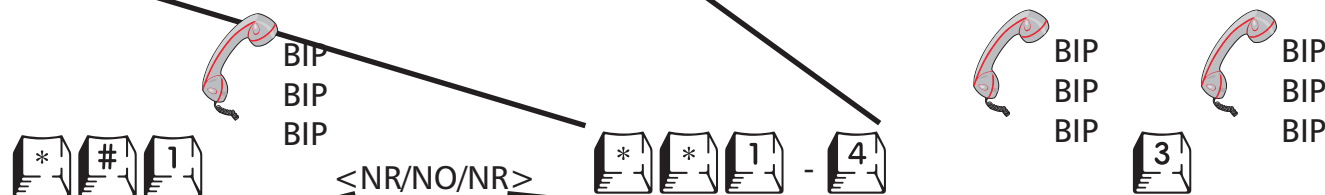

1	wählt/dials/seleziona	1	8	wählt/dials/seleziona	8
2	wählt/dials/seleziona	2	9	wählt/dials/seleziona	9
3	wählt/dials/seleziona	3	0	wählt/dials/seleziona	0
4	wählt/dials/seleziona	4	# # 1	wählt/dials/seleziona	#
5	wählt/dials/seleziona	5	# # 2	wählt/dials/seleziona	*
6	wählt/dials/seleziona	6	# # 3	wählt/dials/seleziona	"PAUSE"
7	wählt/dials/seleziona	7	# # 4	wählt/dials/seleziona	R

- D** Doormaster Smart 4+N Programmierung
- GB** Doormaster Smart 4+N programming
- I** Doormaster Smart 4+N programmazione

Telefonnummer löschen/delete a telephone no./cancellazione nr. telefonico



Tonplan/progress tone plan/piano toni

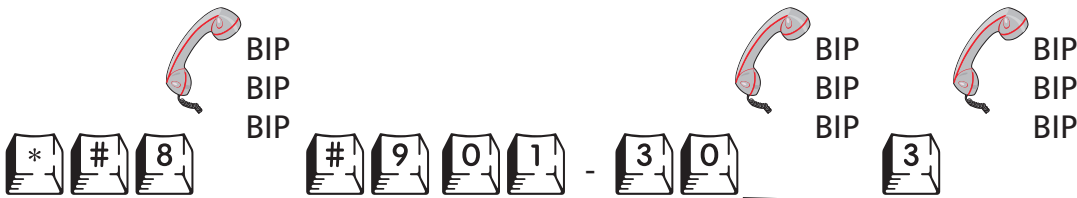

01 = GER, ITA, MEX, POL, LUX	05 = SPA, FRA	09 = USA, CAN, TUR	13 = T-Com
02 = SWE, DEN, ISL, POR	06 = SIN	10 = Agfeo	14 = Tenovis
03 = AUT, FIN, GRE, HUN	07 = BEL	11 = Panasonic	15 = Auerswald
04 = GBR, AUS	08 = CZE	12 = Siemens	16 = Gesko

Bedienungsanleitung/user guide/guida all'uso

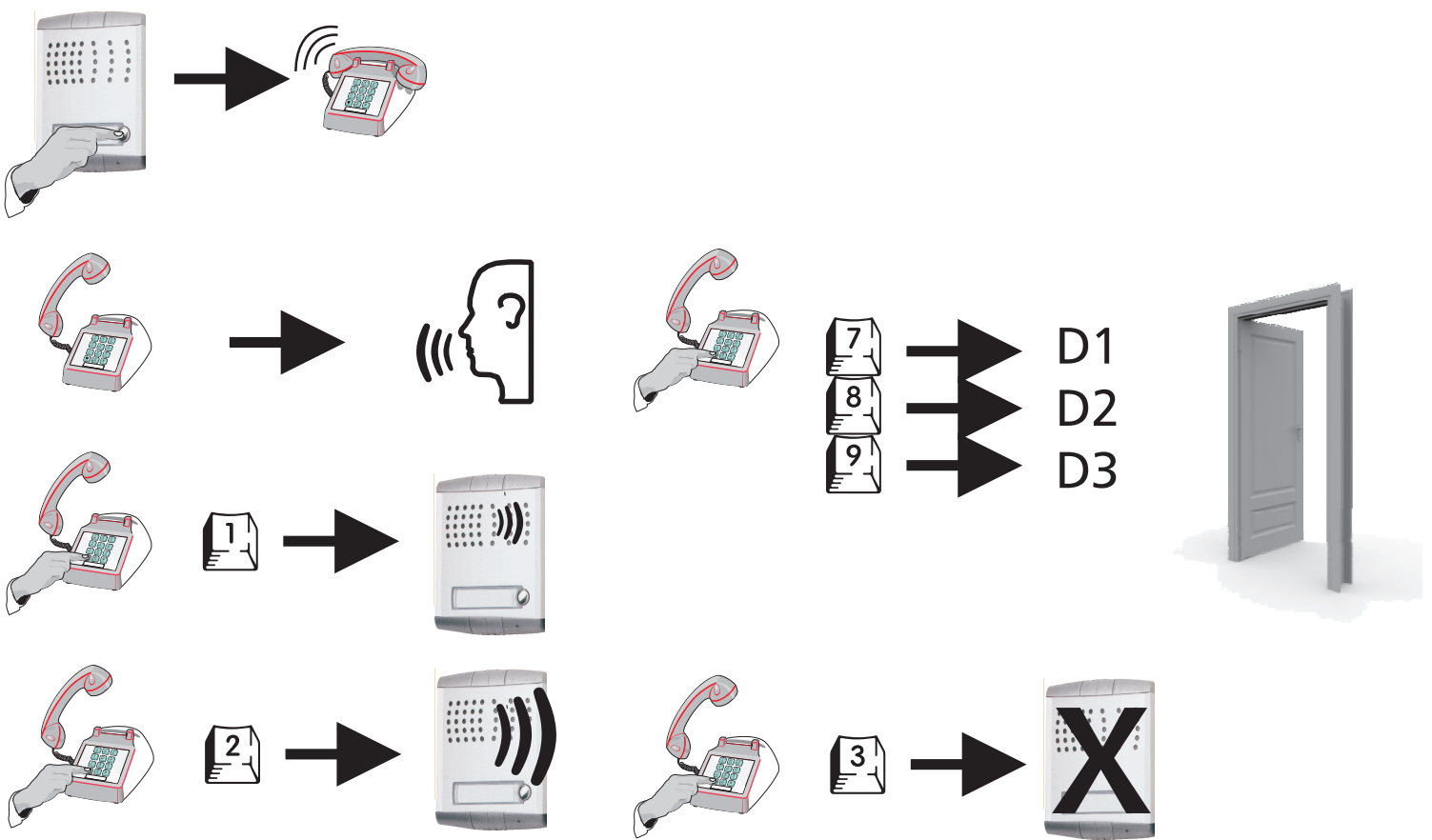

- D** Doormaster Smart 4+N technische Daten
- GB** Doormaster Smart 4+N technical data
- I** Doormaster Smart 4+N dati tecnici

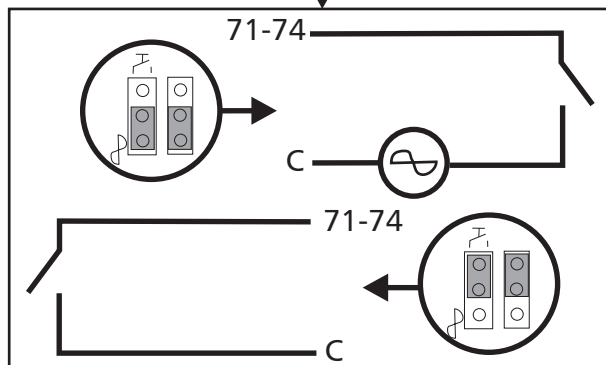
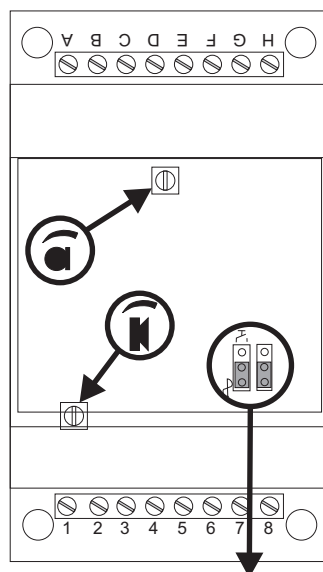
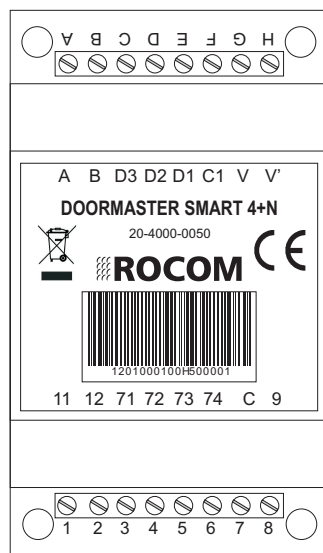

D Doormaster Smart 4+N Anschlussklemmen

- 11 (1): Mikrofon
- 12 (2): Lautsprecher
- 71 (3): Klingeltaste 1 (12 VAC oder potentialfrei)
- 72 (4): Klingeltaste 2 (12 VAC oder potentialfrei)
- 73 (5): Klingeltaste 2 (12 VAC oder potentialfrei)
- 74 (6): Klingeltaste 2 (12 VAC oder potentialfrei)
- C (7): Gemeinsamer Kontakt Klingeltasten 1 bis 4
- 9 (8): Masse der Sprechverbindung (nur DC!)
- A/B (A/B): Analoge Telefonleitung 600 Ohm
- D3 (C): Steuerkontakt 5 (Steuerung "9") max. 1 A/24 Vac/dc
- D2 (D): Steuerkontakt 4 (Steuerung "8") max. 1 A/24 Vac/dc
- D1 (E): Steuerkontakt 3 (Steuerung "7") max. 1 A/24 Vac/dc
- C1 (F): Gemeinsamer Kontakt Steuerkontakte D1/D2/D3
- V/V' (G/H): Stromversorgung max. 12 Vac/dc max. 100 mA

GB Doormaster Smart 4+N connections

- 11 (1): microphone
- 12 (2): loudspeaker
- 71 (3): chime button 1 (powerless or 12VAC)
- 72 (4): chime button 2 (powerless or 12VAC)
- 73 (5): chime button 3 (powerless or 12VAC)
- 74 (6): chime button 4 (powerless or 12VAC)
- C (7): common wire for chime buttons 1 to 4
- 9 (8): speech ground (DC only!)
- A/B (A/B): to analogue telephone line FXS 600 Ohm
- D3 (C): driver contact 5 (controller "9") max. 1 A/24 Vac/dc
- D2 (D): driver contact 4 (controller "8") max. 1 A/24 Vac/dc
- D1 (E): driver contact 3 (controller "7") max. 1 A/24 Vac/dc
- C1 (F): common wire for driver contacts D1/D2/D3
- V/V' (G/H): power supply max. 12 Vac/dc max. 100 mA

I Doormaster Smart 4+N morsetti

- 11 (1): microfono
- 12 (2): altoparlante
- 71 (3): chiamata 1 (contatto pulito o 12 VCA)
- 72 (4): chiamata 2 (contatto pulito o 12 VCA)
- 73 (5): chiamata 3 (contatto pulito o 12 VCA)
- 74 (6): chiamata 4 (contatto pulito o 12 VCA)
- C (7): filo comune per chiamate 1 - 4
- 9 (8): massa fonica (solo CC!)
- A/B (A/B): verso la linea telefonica analogica 600 Ohm
- D3 (C): comando 5 (funzione "9") max. 1 A/24 Vac/dc
- D2 (D): comando 4 (funzione "8") max. 1 A/24 Vac/dc
- D1 (E): comando 3 (funzione "7") max. 1 A/24 Vac/dc
- C1 (F): filo comune per comandi D1/D2/D3
- V/V' (G/H): alimentazione max. 12 Vac/dc max. 100 mA

Quickmarks. Download reader for mobile phone: <http://www.quickmark.com.tw/En/basic/download.asp>



Bedienungsanleitung
Doormaster Smart
komplett, deutsch